



# DEEP AND LARGE AREA CUTTING SERIES

## 大切深加工系列

No. 241216011



影片  
Video

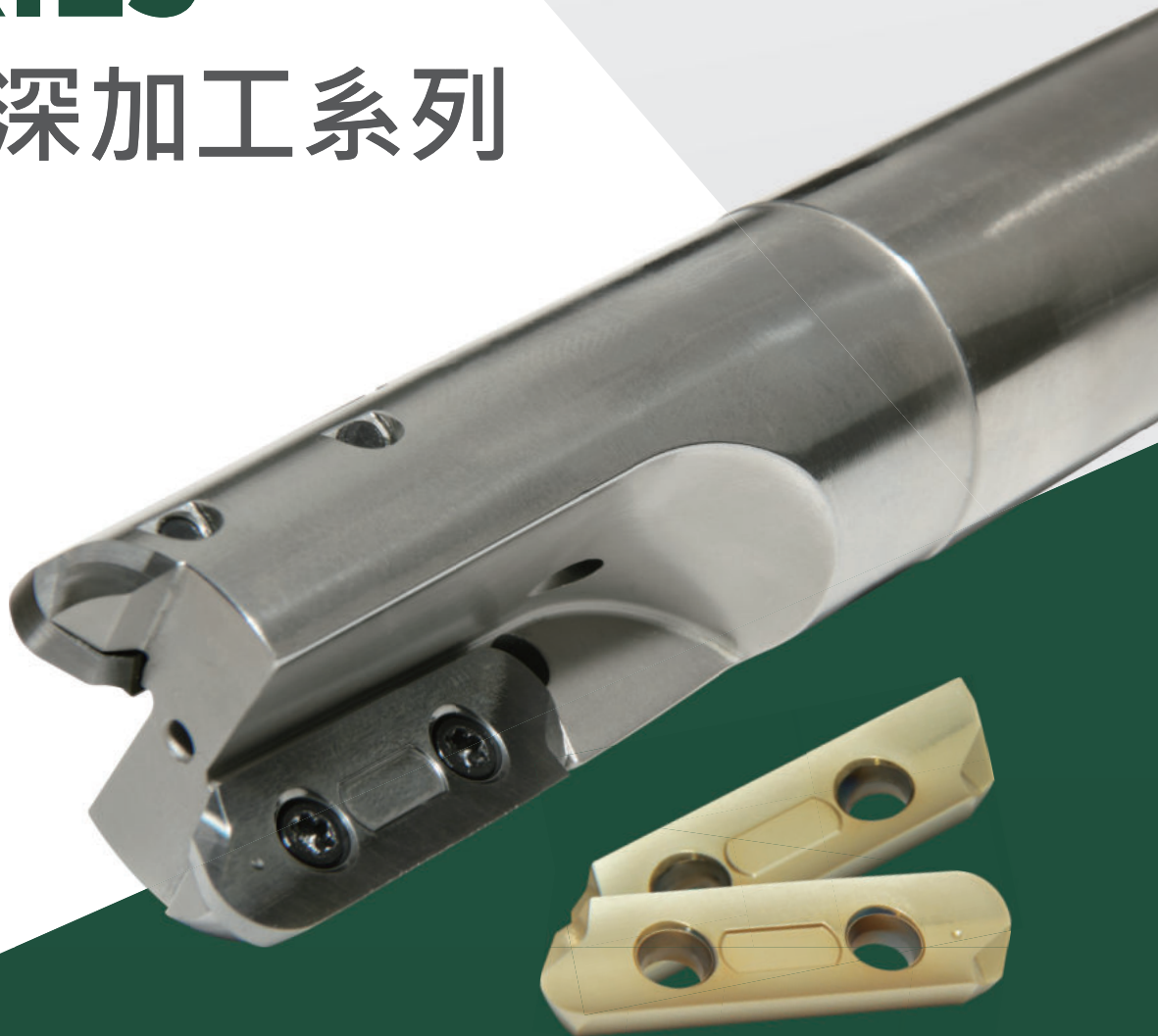

# AECX32T3 長刃型颶風刀片

## AECX32T3 LONG EDGE MILLING INSERT

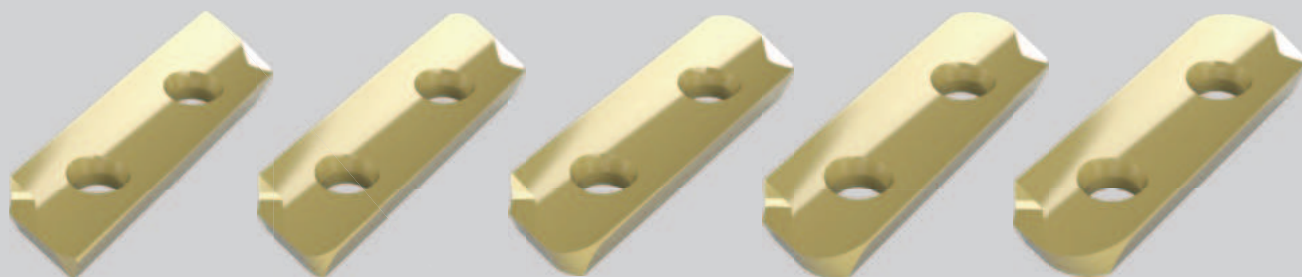

0.2

2.0

3.0

4.0

5.0

### 5 種刀尖圓弧半徑 Five Kinds of Cutting-Edge Radius



鋁合金專用  
For Aluminum



合金鋼專用  
For Alloy Steel

材質 Grade	塗層類型 Coating Type	顏色 Color	特點 Feature	刃口形式 Profile
OM5035	PVD-AICrN	淡金色 Light Gold	<ul style="list-style-type: none"> <li>• 奈米複合膜</li> <li>• 高抗氧化溫度</li> <li>• 表面低親和力</li> <li>• 適用於不銹鋼及鈦合金加工</li> <li>• Nano-composite film</li> <li>• High resistance to oxidation temperature</li> <li>• Low surface affinity</li> <li>• Suitable for processing stainless steel and titanium alloys</li> </ul>	
OM5005	UN-COATING	無 None	<ul style="list-style-type: none"> <li>• 適用於鋁合金、銅合金加工</li> <li>• Suitable for aluminum alloys and copper alloys</li> </ul>	
OM5060	PECVD	彩虹色 Rainbow Colors	<ul style="list-style-type: none"> <li>• 抗沾黏</li> <li>• 低摩擦係數</li> <li>• 有效改善排屑</li> <li>• 適用於鋁合金、銅合金加工</li> <li>• Anti-adhesion</li> <li>• Low friction coefficient</li> <li>• Effectively improves chip evacuation</li> <li>• Suitable for aluminum alloys and copper alloys</li> </ul>	

- ▶ 提供 30mm 大切深需求，並設計 5 種刀尖 R 角，提高切削應用彈性。
- ▶ 刀片採全周研磨及表面拋光，大幅改善加工黏屑問題，並提供特殊 PVD 鍍膜，提高耐磨性及抗熱性。
- ▶ 鋒利切削刃、曲線斷屑槽，使排屑更順暢。

- ▶ 30mm long edge cutting size with 5 kinds of radius designed to offer different application needs.
- ▶ The insert is fully ground and polished, reducing chip adhesion, with a PVD coating for enhanced wear and heat resistance.
- ▶ The sharp cutting edge ensures excellent surface roughness, while the curved chip breaker enables smooth chip removal.

# HRCN 颶風直柄銑刀

## HRCN HURRICANE INDEXABLE MILLING CUTTER

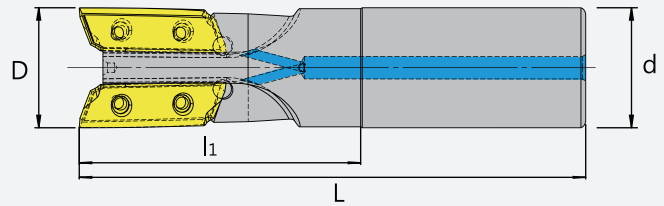

規格 Spec.	L	l <sub>1</sub>	D	d	刃數 Flutes	刀片 Insert	重量 (KGS) Weight
HRCN-3232-AE32-135L-2T-C	135	75	32	32	2	AECX32T302	-
HRCN-3332-AE32-135L-2T-C	135	75	33	32	2	AECX32T320 AECX32T330	-
HRCN-4032-AE32-135L-2T-C	135	75	40	32	2		-
HRCN-4032-AE32-135L-2T-C-A	135	75	40	32	2	AECX32T340 AECX32T350	-

• 註：刀片選用R角4.0以上，需搭配專用刀具。

• Note : Inserts with an R radius of 4.0 or above must be used with designated tooling.

# HRCN 颶風殼形銑刀

## HRCN HURRICANE SHELL MILLING CUTTER

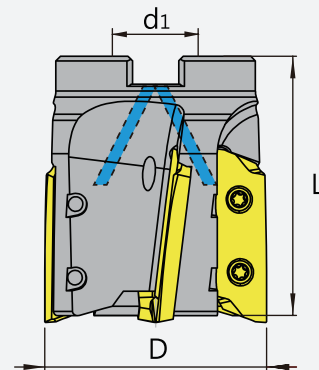
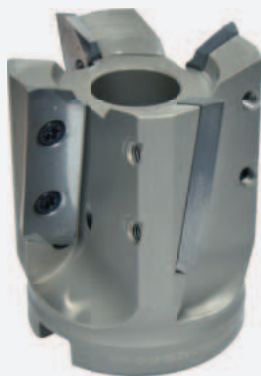



規格 Spec.	L	d <sub>1</sub>	D	刃數 Flutes	刀片 Insert	重量 (KGS) Weight
HRCN-500-FMB22-AE32-4T-C	60	22	50	4	AECX32T302	-
HRCN-630-FMB22-AE32-4T-C	60	22	63	4	AECX32T320 AECX32T330	-
HRCN-800-FMB27-AE32-5T-C	70	27	80	5		-
HRCN-500-FMB22-AE32-4T-C-A	60	22	50	4	AECX32T340 AECX32T350	-
HRCN-630-FMB22-AE32-4T-C-A	60	22	63	4		-
HRCN-800-FMB27-AE32-5T-C-A	70	27	80	5		-

• 註：刀片選用R角4.0以上，需搭配專用刀具。

• Note : Inserts with an R radius of 4.0 or above must be used with designated tooling.

### 配件表 Accessories

刀片 Insert	螺絲  Screw	扳手  Wrench	扭力值 (N.m) Torque
AE..32T3	M4-8.0-5.2-43-T15	T15	3

# CLM長刃型倒角刀

## CLM LONG EDGE CHAMFERING CUTTER

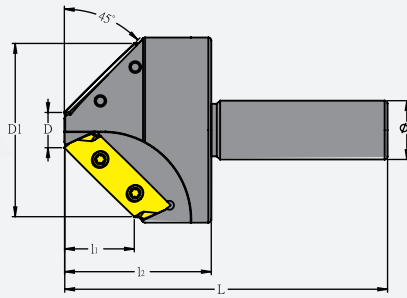
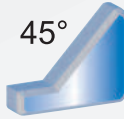

內孔倒角範圍  
Inner Chamfering Range

Min	r	Max
13	r=0.2	58
15	r=2.0	58
17.5	r=3.0	58
19.5	r=4.0	58
21.5	r=5.0	58

規格 Spec.	L	D	D1	d	l <sub>1</sub>	l <sub>2</sub>	功能 Function	刀片 Insert	重量 (KGS) Weight
CLM-5920-110L-AE32	110	12	59	20	23.7	50	倒角 Chamfering	AECX32T302	0.7
CLM-5932-110L-AE32	110	12	59	32	23.7	50	倒角 Chamfering	AECX32T302	0.9

- 註：如需底部加工功能，刀具體需局部微調修改。
- Note: If bottom machining is required, the tool body will need partial adjustments or modifications.

# AECX32T3 長刃型颶風刀片

## AECX32T3 LONG EDGE MILLING INSERT

ISO 分類	P	合金鋼 Alloyed Steels				●			切削狀態 Cutting Condition:  ● 連續切削 Continuous Cutting ○ 一般切削 General Cutting ■ 斷續切削 Interrupted Cutting
	M	不鏽鋼 Stainless Steels				●			
	K	鑄鐵 Cast Iron							
N	鋁及鋁合金 Aluminum&Al	●	●						
S	高溫合金 Refractory Alloys								
H	高硬度材 Hard Material								
形狀 Shape	規格 Spec.	超微粒硬質合金 Micro grain cemented carbide			尺寸 (mm) Size				圖形 Drawing
		HF							
		OM5005	OM5060	OM5035	d	i	s	r	
	NEW AECX32T302ER-F01	●	●	●	11.9	37	3.97	0.2	
	NEW AECX32T320ER-F01	●	●	●	11.9	37	3.97	2	
	NEW AECX32T330ER-F01	●	●	●	11.9	37	3.97	3	
	NEW AECX32T340ER-F01	●	●	●	11.9	37	3.97	4	
	NEW AECX32T350ER-F01	●	●	●	11.9	37	3.97	5	

## AECX32\_銑削 切削條件數據表 Milling Cutting Parameter

被加工材質 Machining Materials	刀片材質 Grade	切削速度 Vc(m/min)	每刃進給 (mm)
P 合金鋼 Alloyed Steels	OM5035	120~160	0.06~0.12
M 不鏽鋼 Stainless Steels	OM5035	80~130	0.06~0.10
N 鋁合金 Aluminum&Al	OM5005	500~1800	0.05~0.25
	OM5060	500~1800	0.05~0.25

- 註：倒角切削參數直徑設定，建議中間值D=25mm，再依實際情況微調。
- Note: It is recommended to use a median value of D=25mm for the chamfering parameter diameter setting, and then adjust based on actual conditions.

# HRCN加工應用 HRCN Applications



台階面銑削  
Step Milling

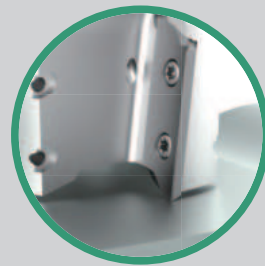

平面銑削  
Face Milling



腔體銑削  
Cavity Milling



曲面銑削  
Contour Milling

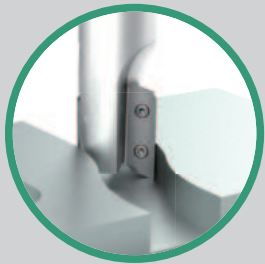

開槽銑削  
Groove Milling

# CLM加工應用 CLM Applications

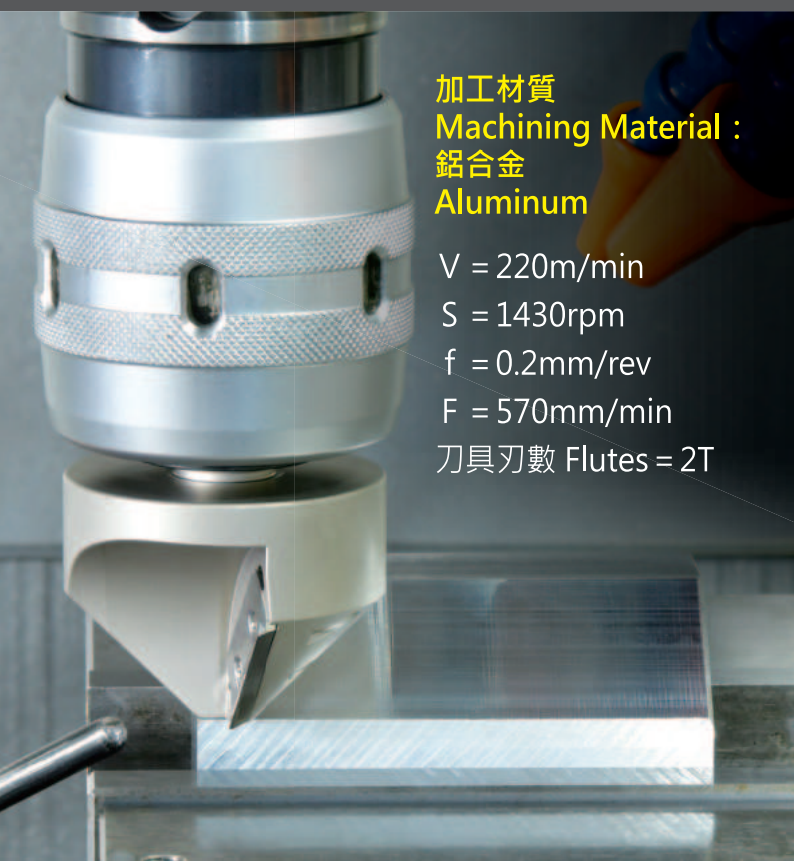

加工材質  
Machining Material :  
鋁合金  
Aluminum

$V = 220\text{m/min}$   
 $S = 1430\text{rpm}$   
 $f = 0.2\text{mm/rev}$   
 $F = 570\text{mm/min}$   
刀具刃數 Flutes = 2T



加工材質  
Machining Material :  
合金鋼  
Alloy Steel

$V = 160\text{m/min}$   
 $S = 1040\text{rpm}$   
 $f = 0.12\text{mm/rev}$   
 $F = 250\text{mm/min}$   
刀具刃數 Flutes = 2T



正河源股份有限公司  
CHAIN HEADWAY CO., LTD.

☎ 電話 TEL /  
+886-4-26265252

☎ 傳真 FAX /  
+886-4-26267941

📍 地址 Address /  
436037台灣台中市清水區五權路232號  
No. 232, Wuquan Rd., Qingshui Dist., Taichung City 436037, Taiwan

🌐 網址 Website /  
[www.chain-headway.com](http://www.chain-headway.com)



公司官網(中文)



Website(EN)



LINE



WeChat



Facebook



YouTube