

VE-SC 同動求心虎鉗

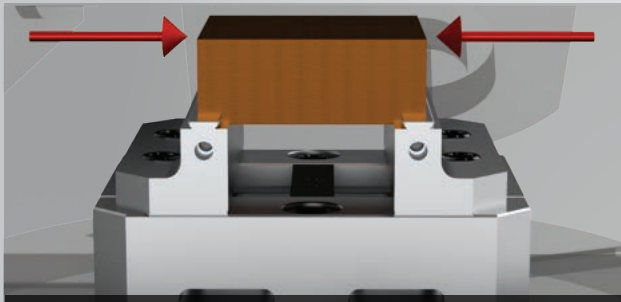

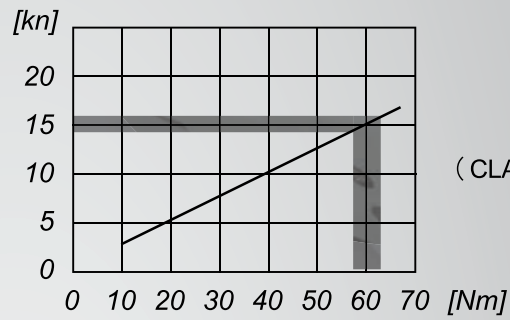

兩個鉗口同步打開或關閉，同時往虎鉗中心移動。
The two jaws open or close synchronously, move to the center of the vise at the same time.



夾持曲線圖
(CLAMPING CURVE)

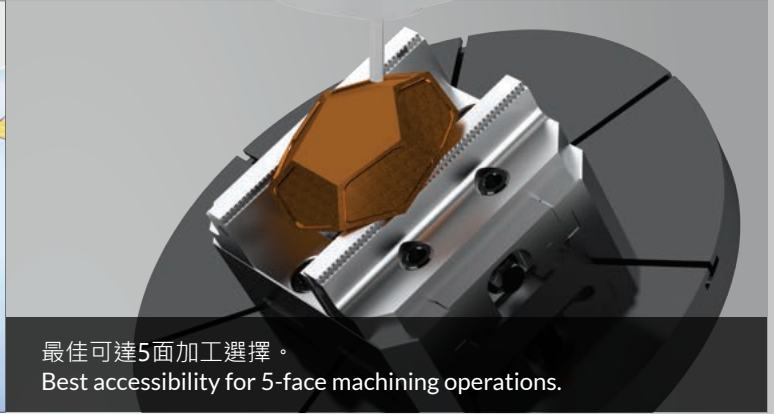
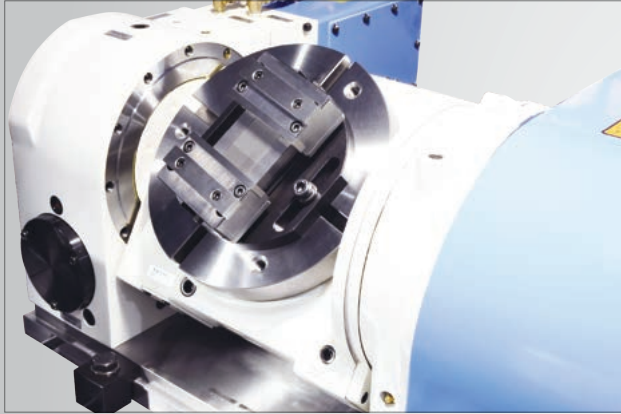

最佳可達5面加工選擇。
Best accessibility for 5-face machining operations.

特點

Features

同動式求心虎鉗適用於三、四、五軸、CNC分度盤及臥式銑床精密加工

Self Centring Precision Vise is suitable for 3、4、5 axis、CNC Rotary Table and Horizontal machining.

虎鉗中心重覆定位精度可保持 $\pm 0.01\text{mm}$ ，極其扁平的設計，為了最大限度地利用機台空間。

Vise precision of its center repetition position is $\pm 0.01\text{mm}$, extremely flat design, for maximum utilization of the machine room.

虎鉗滑軌經高週波熱處理HRC45°以上，可保持高耐磨性。

Slideway has high frequency heat treatment at HRC45° or more to keep the accuracy and its long use life.

虎鉗鉗口採用全鋼材質，經熱處理硬度達HRC55°以上，可拆換方向使用，變化性與互換性極佳。

Vise hard jaw material is full Steel and heat treatment at HRC55° or more. Owing to its good design to use both sides of jaw since it is exchangeable.

虎鉗特殊的結構設計，夾持工件時所產生的下壓力能有效防止工件上浮情形，鎖固力極佳。

Special design for the Self Centring Precision Vise to prevent work piece from bending during clamping and machining. Thus, it has the best solution in clamping the work piece.

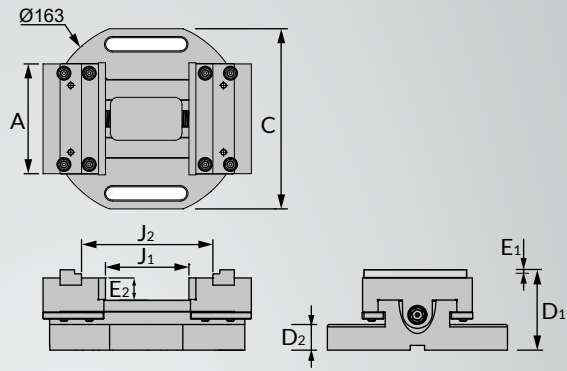

本體材質:合金鋼 Using alloy steel

規格 Spec	A	C	D1	D2	E1	E2	J1	J2	Power	重量 Weight
LM-VE-90SC	90	151	60	17	5	18	0-60	40-100	15KN	4KG

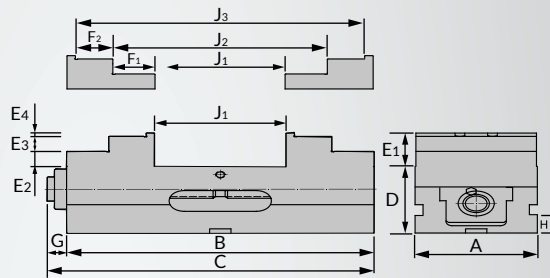

本體材質:球墨鑄鐵 Using FDC60

規格 Spec	A	B	C	D	E1	E2	E3	E4	F1	F2	G	H	J1	J2	J3	Power	重量 Weight
LM-VE-60SC	60	120	143	60	25	12.5	12.5	-	17.5	-	23	18	0-50	38-85	-	15KN	6KG
LM-VE-100SC	101	240	260	80	40	18	18	4	35	31	20	22	0-90	70-160	134-222	15KN	16KG
LM-VE-160SC	160	370	440	105	55	27.5	27.5	-	42.5	-	70	22	0-200	86-285	-	18KN	47KG

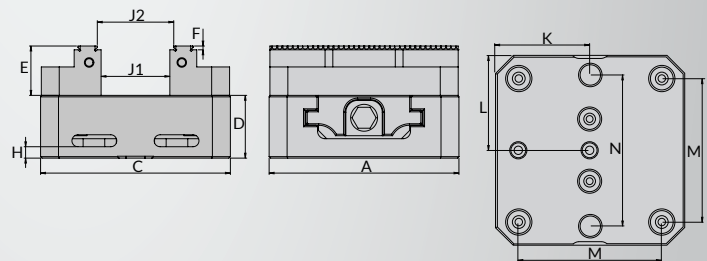

本體材質:合金鋼 Using alloy steel

規格 Spec	A	C	D	E	F	H	J1	J2	K	L	M	N	Power	重量 Weight
LM-VE-127SC	126	127	42	33	2.54	7.62	0-46	0-51	63.5	63.5	96	101	15KN	5.5KG
LM-VE-153SC	126	153	42	33	2.54	7.62	0-72.5	0-79	76.5	63.5	96	101	15KN	6.7KG
LM-VE-210SC	126	210	42	33	2.54	7.62	0-122	0-127	101.5	63.5	96	101	18KN	8.7KG





正河源機械配件有限公司

CHAIN HEADWAY MACHINE TOOLS CO., LTD

 +886-4-26265252

 +86-0512-57874601

 +886-4-26267941

 +86-0512-57874602

 台灣台中市清水區高美路231巷15號

 中國江蘇省昆山市陸豐東路模具城J區12號樓

 www.chain-headway.com

 youtube.com/chmt99

 twitter.com/ChainHeadway

 [facebook.com/ChainHeadway\(Taiwan/Myanmar/Philippines/India\)](https://facebook.com/ChainHeadway(Taiwan/Myanmar/Philippines/India))

公司聯絡資訊請帖此處

其他服務據點訊息透過官網查詢