

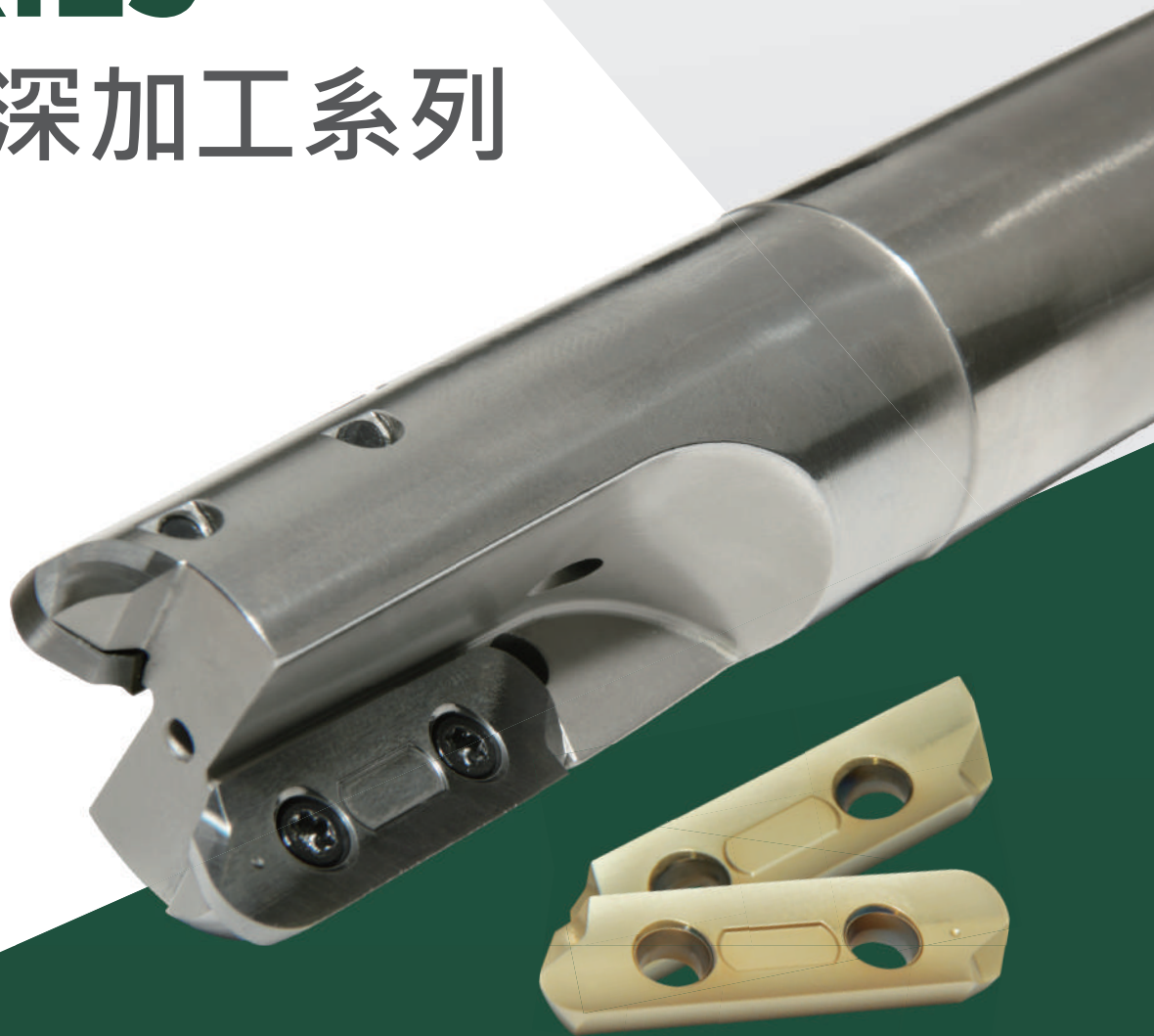

DEEP AND LARGE AREA CUTTING SERIES

大切深加工系列

No. 230607005



AECX32T3 長刃型颶風刀片

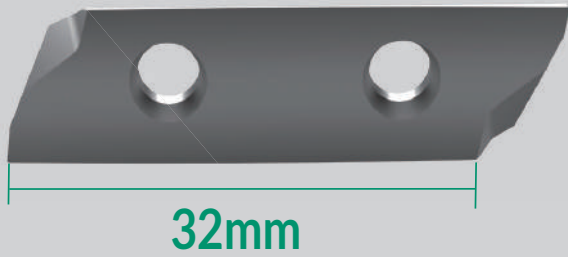

AECX32T3 LONG EDGE MILLING INSERT

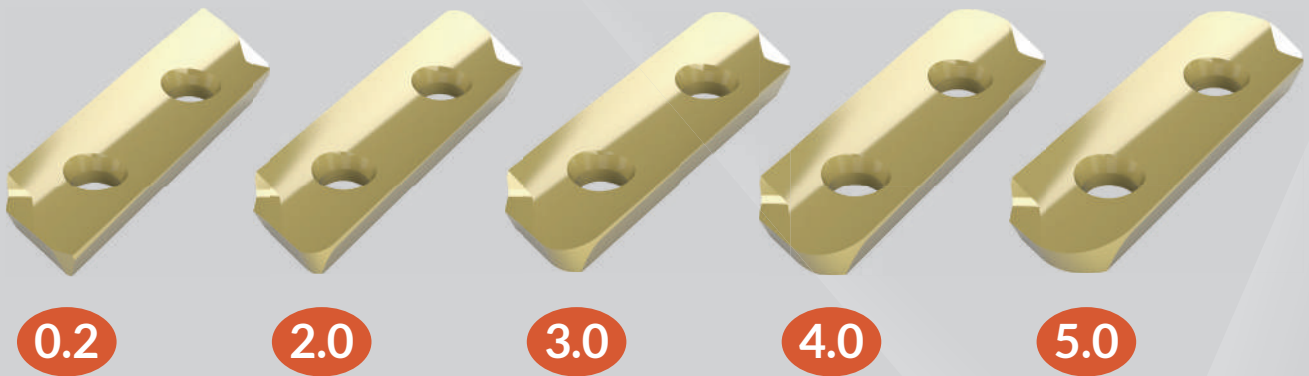

5 種刀尖圓弧半徑 Five Kinds of Cutting-Edge Radius

- ▶ 提供 30mm 大切深需求，並設計 5 種刀尖 R 角，提高切削應用彈性。
- ▶ 刀片採全周研磨及表面拋光，大幅改善加工黏屑問題，並提供特殊 PVD 鍍膜，提高耐磨性及抗熱性。
- ▶ 鋒利切削刃、曲線斷屑槽，使排屑更順暢。
- ▶ 30mm long edge cutting size with 5 kinds of radius designed to offer different application needs.
- ▶ Applied outer diameter grinding with surface polishing on inserts to adjust chip removal issue; Using special PVD coating to improve wear resistance and heat resistance.
- ▶ Sharp cutting edge provides perfect surface roughness; Curved chip breaker provides smooth chip removal ability.



HRCN 颶風直柄銑刀

HRCN HURRICANE INDEXABLE MILLING CUTTER

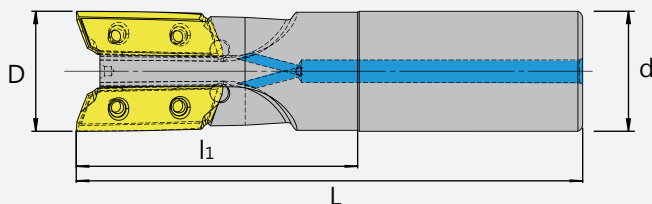

規格 Spec.	L	l ₁	D	d	刃數 Flutes	刀片 Insert	重量 (KGS) Weight
HRCN-3232-AE32-135L-2T-C	135	75	32	32	2	AE..32T3	-
HRCN-3332-AE32-135L-2T-C	135	75	33	32	2	AE..32T3	-
HRCN-4032-AE32-135L-2T-C	135	75	40	32	2	AE..32T3	-



HRCN 颶風殼形銑刀

HRCN HURRICANE SHELL MILLING CUTTER

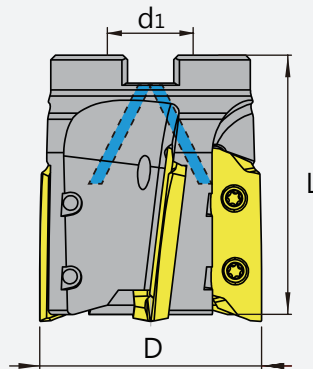

規格 Spec.	L	d ₁	D	刃數 Flutes	刀片 Insert	重量 (KGS) Weight
HRCN-500-FMB22-AE32-4T-C	60	22	50	4	AE..32T3	-
HRCN-630-FMB22-AE32-4T-C	60	22	63	4	AE..32T3	-
HRCN-800-FMB27-AE32-5T-C	70	27	80	5	AE..32T3	-

配件表 Accessories

刀片 Insert	螺絲 Screw	扳手 Wrench	扭力值 (N.m) Torque
AE..32T3	M4-8.0-5.2-43-T15	T15	3

CLM長刃型倒角刀

CLM LONG EDGE CHAMFERING CUTTER

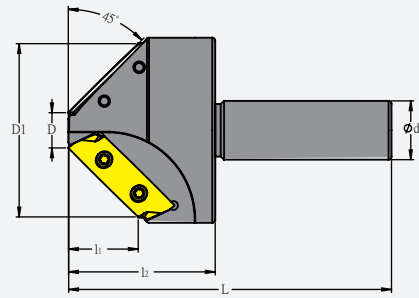
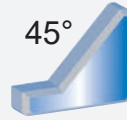

特點 Feature

- 採用 AECX32T3 刀片，可加大範圍倒角，倒角範圍 $\varnothing 13\sim 58\text{mm}$ 。

- Using AECX32T3 long edge insert to extend the chamfering range (from $\varnothing 13\sim 58\text{mm}$).

規格 Spec.	L	D	D1	d	l ₁	l ₂	功能 Function	刀片 Insert	重量 (KGS) Weight
CLM-5920-110L-AE32	110	12	59	20	23.7	50	倒角 Chamfering	AECX32T3	0.7
CLM-5932-110L-AE32	110	12	59	32	23.7	50	倒角 Chamfering	AECX32T3	0.9

AECX32T3 長刃型颶風刀片

AECX32T3 LONG EDGE MILLING INSERT

ISO 分類	P	合金鋼 Alloyed Steels							切削狀態 Cutting Condition : ● 連續切削 Continuous Cutting ○ 一般切削 General Cutting ■ 斷續切削 Interrupted Cutting		
	M	不鏽鋼 Stainless Steels									
	K	鑄鐵 Cast Iron									
	N	鋁及鋁合金 Aluminum&Al	■	○							
	S	高溫合金 Refractory Alloys									
	G	高硬度材 Hard Material									
形狀 Shpae	規格 Spec.	超微粒硬質合金 Micro grain cemented carbide				尺寸 (mm) Size				圖形 Drawing	
		HF				d	i	s	r		
		OM5005	OM5060	OM5035							
	NEW	AECX32T302ER-F01	●	●	●		11.9	37	3.97	0.2	
	NEW	AECX32T320ER-F01	●	●	●		11.9	37	3.97	2	
	NEW	AECX32T330ER-F01	●	●	●		11.9	37	3.97	3	
	NEW	AECX32T340ER-F01	●	●	●		11.9	37	3.97	4	
	NEW	AECX32T350ER-F01	●	●	●		11.9	37	3.97	5	

AECX32_ 切削條件數據表 Cutting Parameter

	被加工材質 Machining Materials	刀片材質 Grade	切削速度 Vc(m/min)	每刃進給 (mm)
P	合金鋼 Alloyed Steels	OM5035	120~160	0.06~0.12
N	鋁合金 Aluminum&Al	OM5005	500~1800	0.05~0.25
		OM5060	500~1800	0.05~0.25

HRCN加工應用 HRCN Application



台階面銑削
Step Milling

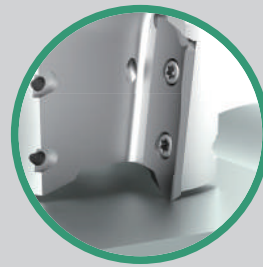

平面銑削
Face Milling



腔體銑削
Cavity Milling



曲面銑削
Contour Milling

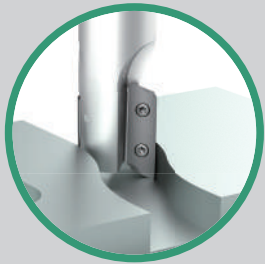

開槽銑削
Groove Milling

CLM加工應用 CLM Application

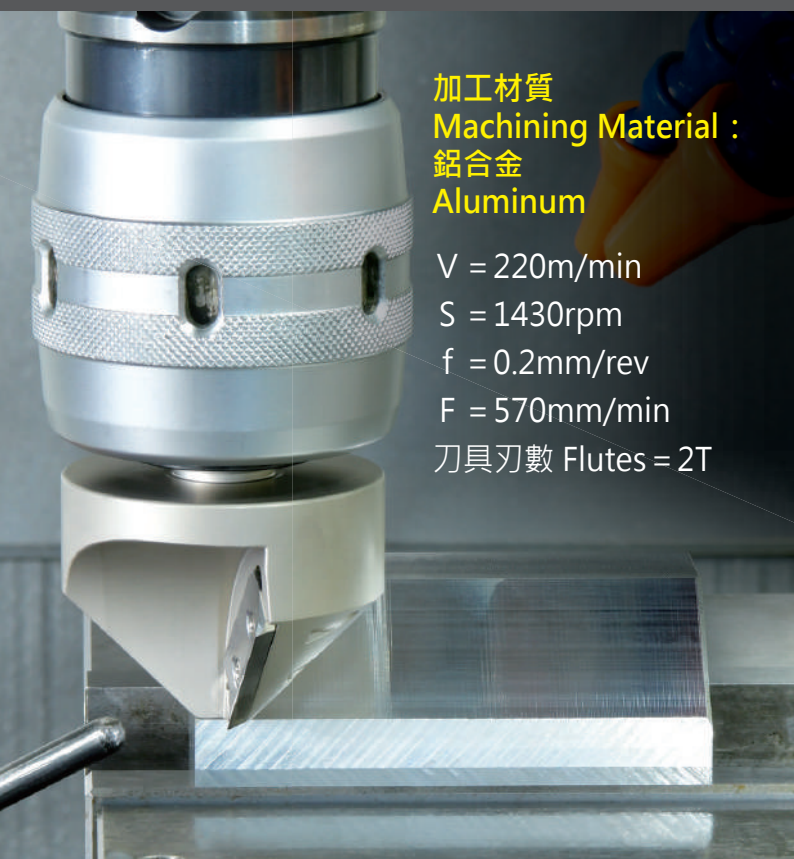

加工材質
Machining Material :
鋁合金
Aluminum

$V = 220\text{m/min}$
 $S = 1430\text{rpm}$
 $f = 0.2\text{mm/rev}$
 $F = 570\text{mm/min}$
刀具刃數 Flutes = 2T

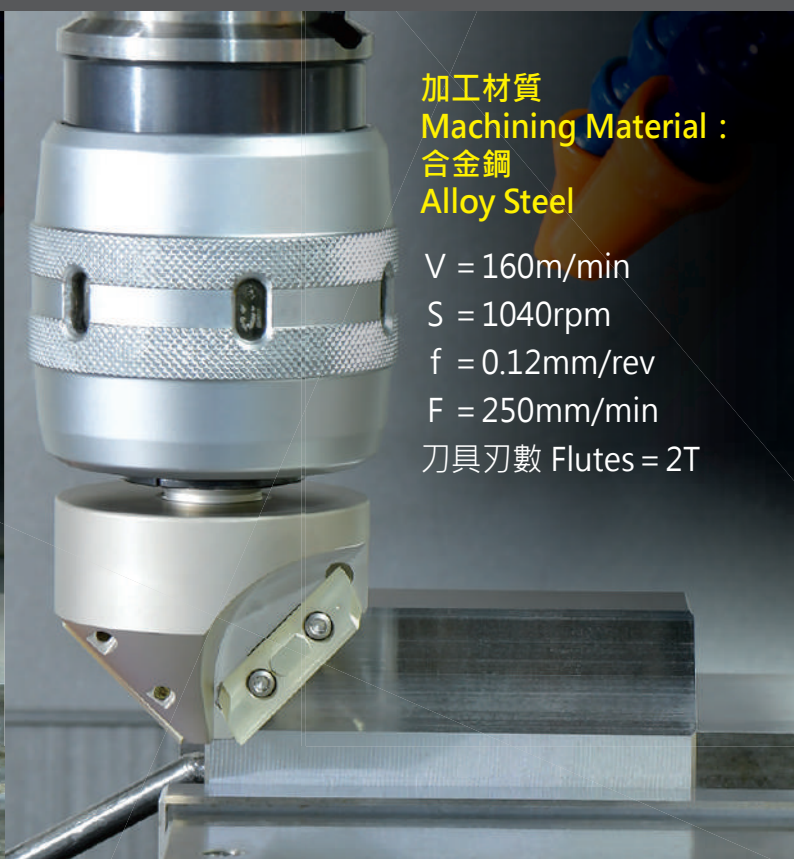

加工材質
Machining Material :
合金鋼
Alloy Steel

$V = 160\text{m/min}$
 $S = 1040\text{rpm}$
 $f = 0.12\text{mm/rev}$
 $F = 250\text{mm/min}$
刀具刃數 Flutes = 2T



正河源股份有限公司
CHAIN HEADWAY CO., LTD.

☎ 電話 TEL /
+886-4-26265252

☎ 傳真 FAX /
+886-4-26267941

📍 地址 Address /
436037台灣台中市清水區五權路232號
No. 232, Wuquan Rd., Qingshui Dist., Taichung City 436037, Taiwan

🌐 網址 Website /
www.chain-headway.com



公司官網(中文)



Website(EN)



LINE

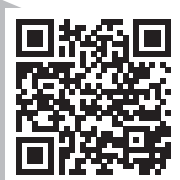

WeChat



Facebook



YouTube