



Cutting Edge Solution

Chain Headway Group



The key to successful corporate management lies in operation in both objective and subjective conditions, where the former of the present time is beyond our control, but the latter, i.e., the subjective managerial condition can be created by the Company's managing team. In the inevitable tendency of market competition, it is critical to forge the Company's core competitiveness. Driven by the company's strategy for development (Channel-Value-Added-Platform, CCVP), in 2019, our local tactical applications were changed with time.

First, in respect to the markets, the Company developed the Southeast Asian market by carrying out deep-rooted localized operation; in the Indian market, a branch was established to conduct localized operation, too; in China, the business strategy was changed to basing in Eastern China as the center for expanding to other provinces, with more resources pumped into the Chinese market particularly this year. In response to the applications of smart, automatic production tools being more focused on quality stability and performance increase, our merchandise integration is changed as well, while the investment and production of European and Japanese equipment and the merchandise integration thereof also provide best cutting benefits.

In respect to talent fostering, the Company is concentrated on the corporate core values (responsibility) and introduced industrial-academic collaboration programs to build a platform for workplace development, improve living quality for employees and reinforce competitiveness in the industry. Besides, how to respond to the business model in the age of discontinuity in future (looking at the present from the future) is a more important issue to focus on. Furthermore, what is essential as emphasized by our White Paper for Golden Decade Strategy is that the foci of our business development include the combination of cutting systems and fixing & jig systems, customization for our clients, enhancement of processing efficacy, and to exhibit the Company's values.



INNOVATIVE

RELIABLE

STABILITY

Innovative R&D & Quality Stability that Keep Up with Time

In order to effectively serve our supporting partners, we have been constantly extending our service stations and, by committing to developing products that the markets need, we have kept upgrading our existed products as well. We also keep on on-job training in personnel's specialized services, maintaining fast delivery mode and connecting the world's industries to advance toward the goal of leading in technology.



Loyalty, Honor



Life symbolizes thriving,
meaning commencement and smooth flow

Brand Spirit and Corporate Values

Hand in hand with partners, head for development

Since 2013, CHAIN HEADWAY has hoped to create maximum value of the corporate brand by Corporate Identity System. It is a hope that, in line with CHAIN HEADWAY's motto for service - to meet customer's need for processing in a fast manner - it would be more possible to demonstrate CHAIN HEADWAY's core philosophy in its corporate image, brand identification, product packaging, and exhibition image overall.

CHAIN HEADWAY uses the symbol of "CC" as its main corporate identity, where the green "C" means the Company's life symbolizing thriving, which means commencement and smooth flow, and the orange "C" means loyalty and honor of customers, implying the vitality and loyalty of smooth collaboration between CHAIN HEADWAY and customers. The interlocking double C carries the hope of building close cooperation with customers and forging brand new service quality, to become a partner whom customers trust.



Precision Chucks

As early as 1991, CHAIN HEADWAY has begun the marketing of machine accessories, precision milling tools and chucks under the "SYIC" brand, which gained good reputation among peers in machinery industry.



Cutting Tools

In 1994, CHAIN HEADWAY has begun the input of funds, talents and technology to develop cutting tools.



Assisting Tools

In 1999, the marketing of assisting tools under the brand name of LEMMA was launched to satisfy our clients' need for a total solution.



Corporate Values



Innovation

This is the foundation for CHAIN HEADWAY's core abilities. Only by persisting in constant innovation, including product innovation, managerial innovation, organizational innovation, information innovation, technology innovation, service innovation and quality advance, along with effective integration can the Company work out the true benefits of innovation. This is the way of sustainable business for the technological industry that is evolving each day.



Speed

This is the essence of CHAIN HEADWAY's cultural values, as time is the greatest cost in competition. We pursue the intensity and speed of research and development to constantly satisfy the clients' needs for processing. As customers' expectation for products has been the target of CHAIN HEADWAY, we keep on pursuing to surpass the goals of speed of new item cycle, speed of quality inspection, speed of delivery and speed of service.



Integrity

This is the value that CHAIN HEADWAY persists in most and the competitive edge that CHAIN HEADWAY most treasures. In keeping sound cooperative relationships with its employees, clients and partners, CHAIN HEADWAY must stick to its principle of integrity. As only insisting in doing the right things is our corporate value that cannot be replaced by whatsoever, the principle of integrity is CHAIN HEADWAY abides by in managing the business.



Responsibility

This is the important cornerstone for CHAIN HEADWAY to continue developing. Whatever we've take from the society, we shall give them back and make contribution to the society. As the society is the environment which we exist in, its development and corporate development are the crucial factors that affect CHAIN HEADWAY's sustainable development. Besides corporate development, we take social advance more importantly during our business management. The Company leads its employees to be friendly to the environment, conserve energy, beautify our surrounding and care about the society. Under CHAIN HEADWAY's developing policies, social responsibility is always an unchanged idea.

Initial Intention of Contribution to Industry

We keep up with the time and work with you to lead in technology

1990

Chain Headway Origin
Place QingShui
Gaomei Wetland &
AoFong Mountain



1990

1991-1995

Business of machine accessories.



1995

2000

2005

2001-

Change
Collabo
expand



1996-2000

Extension of market by setting foot
in China market.



Cooperation with European & US tool
makers to increase market quality and
share resources.

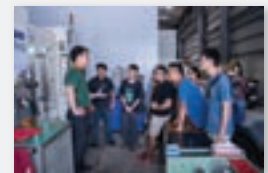

2006-2010

Talent fostering
Industrial-academic cooperation.

2001-2005

Change of business model
Collaboration with partners to
expand distribution channels.

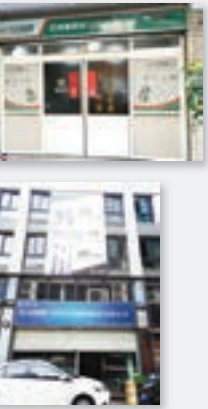

2011-2015

Quality reengineering & efficiency
enhancement
Receipt of awards.



2010

2015

2019

FUTURE



2016-2019

Preparation for deployment in Southeast Asia.
Keep up the time. Root in high-end equipment
business and take good control of quality.

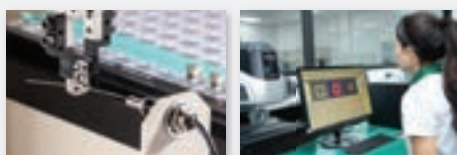

High-end facilities for full control of quality.



March into 2020

HQ Building inaugurated for
expanded operation and
leading in technology to go
global.

Honor and Recognition

CHAIN HEADWAY gained recognition among the industry through its efforts and experience over years.

2010

- ACM - Golden Pin Design Mark
- SCM - Golden Pin Design Mark
- ACM - Taiwan Excellence Award

2017

- HCM Aluminum Alloy Face-Milling Cutter (Dynamic Balance & Internal Coolant Structure) Taiwan Excellence Award

2011

- CBMC - Golden Pin Design Mark
- CSBJ - Golden Pin Design Mark
- TTQS (Talent quality management system) Bronze medal

2018

- A-Team 4.0 Golden Award

2012

- BR - Golden Pin Design Mark
- CSBJ coolant - Golden Pin Design Mark

2013

- TCS Torque Tapping Extender Replacement Kit - Golden Pin Design Mark
- Octagonal Positioning Rounded Corner End Mill Blade - Golden Pin Design Mark

2015

- R&D in SBIR Light-Weight Aluminum Alloy Cutter - Taiwan SMEs Innovation Award
- Aluminum Alloy Face-Milling Cutter – German Patent Nr. 20 2015 102 712
- Aluminum Alloy Face-Milling Cutter – Golden Pin Design Mark
- Aluminum Alloy Face-Milling Cutter – Taiwan Excellence Award





Effectively Solve the Needs for Processing

In the tendency of expensive energy and material costs, the material cycle, efficacy and wear of materials become a focus of development in every industry.

For CHAIN HEADWAY who has done research in the area of tool cutting for nearly three decades, whether in drilling, chamfering, tapping, milling, turning/thread cutting, slotting/severing, or boring, “stability” and “accuracy” have become basic thresholds for tools. In the future, the Company will be targeting at “versatility” and “exclusivity”, and employ the former to realize single equipment capable of more diverse process types and the latter to get out of the old box of standard products. With these two objectives, the Company will exercise design of customized tools and craft analysis, making breakthrough in existing processes and seeking higher efficacy to achieve the purpose of high efficiency and low consumption. In the analysis of crafts of cutting positions, model design, post-process crafts, test statistics and data analysis are used to present product improvement programs for enhancing product performances.



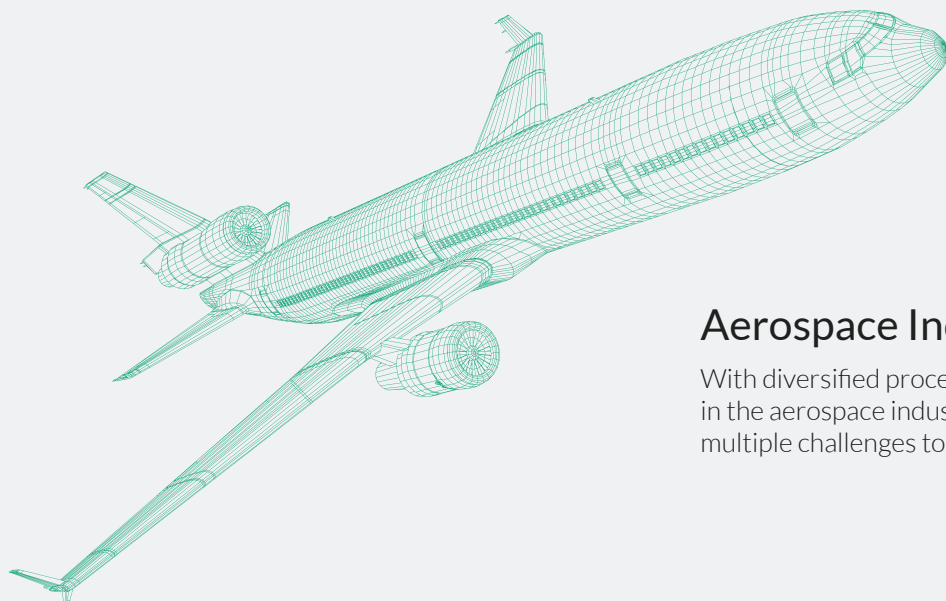

Aerospace Industry

With diversified processing of the special materials used in the aerospace industry, such processing also poses multiple challenges to manufacturers in the industry.

For Your Business

We provide customized services to your industry.

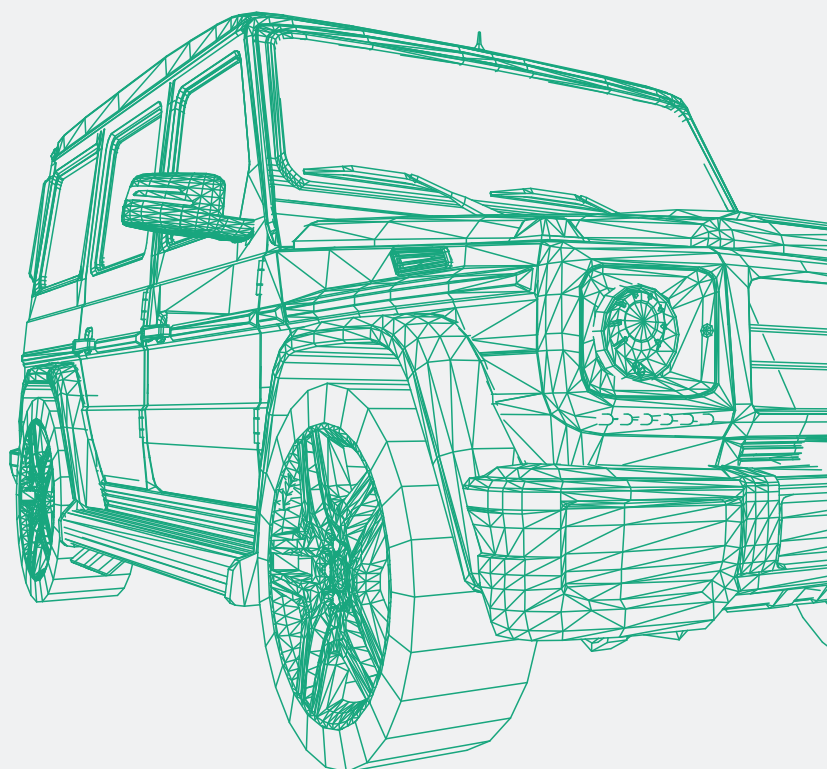
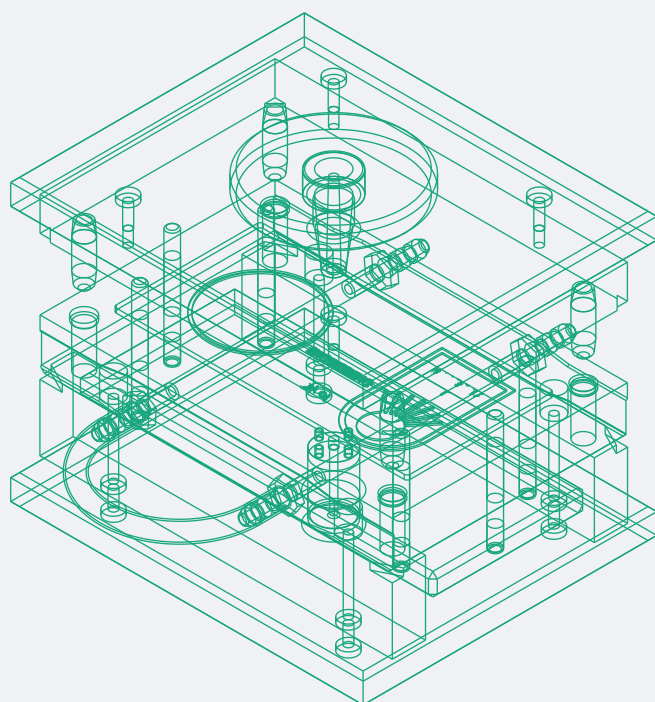

Specialized Services for Different Industries

CHAIN HEADWAY sells as many as 22,000 items of products as well as provides services of customized products to solve any processing need. We have specialized personnel who are able to offer best integrated programs to generate maximum production benefits for clients. CHAIN HEADWAY offers integrated programs of cutting and innovatively developed products to help our clients take full advantage ahead of others in this ever-changing industry.

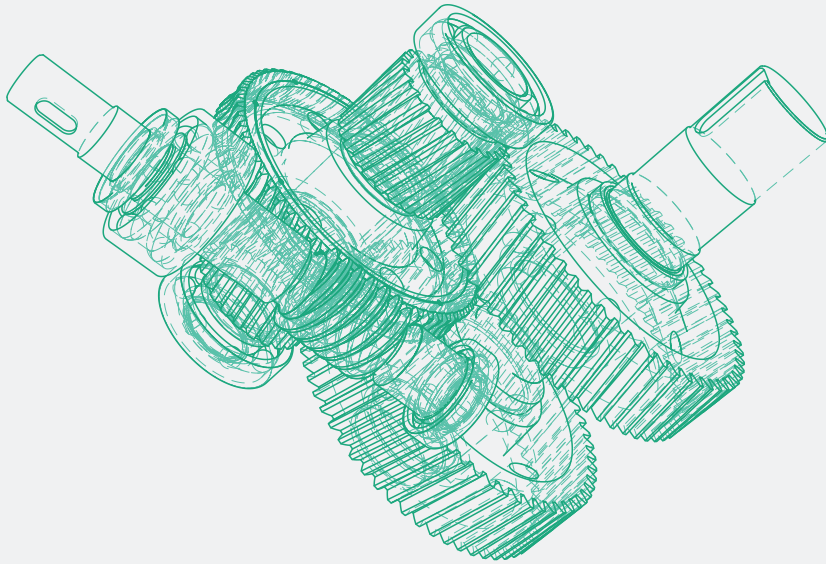

General Processing Industries

As the greatest challenge faced in processing general is speed and price, choosing the right processing tools is inevitable.

Mold Industry

The development of the mold & die industry is closely related to industrial development. To respond to increasingly shorter product life cycles, the production of molds should be faster and faster, too.

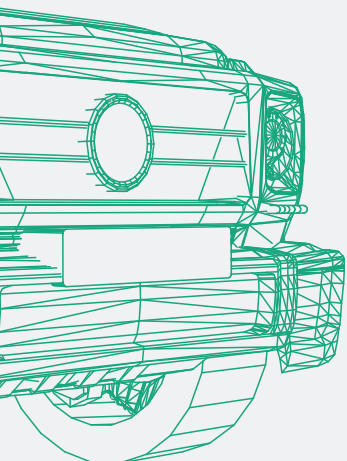

Automotive Industry

In view that the fast development of the automotive industry requires light-weight materials and special applications, we offer solutions with cutting-edge tools.

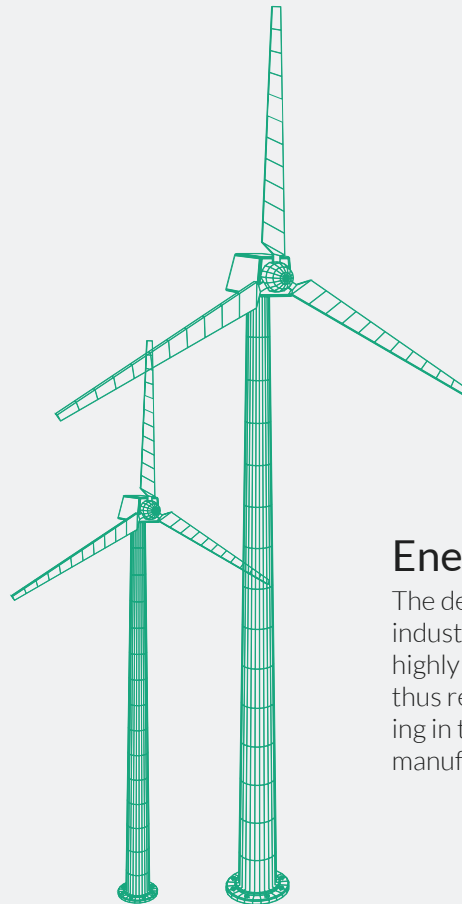

Energy Industry

The development of the energy industry depends upon durable and highly efficient raw materials; it is thus remarkably strict and demanding in the course of production and manufacture.



CHAIN HEADWAY's Specialized R&D Team

Be it heavy process, light process or ordinary process, a number of particular processing conditions or non-general processing conditions that technicians encounter are without doubt distressful for the technicians.

The specialized teams of technology and design at CHAIN HEADWAY are able to help you solve your specific needs in least time. With abundant experiences in various industrial fields over years, we are able to accurately design tools and clamping systems customized for you. We trust that to possess good specialized technology teams as your good partner is sure to enhance your productivity and benefit significantly.



Our Specialized Technology and Design for Your Special Needs

Time + Efficiency + Stability = Benefits

We are dedicated to planning on better innovated and more efficient customized service for you.



Effectively help
improve production
process



Increase tool life
Increase productivity



Optimize processes
for mass
production planning



We Insist on Rigorous of Every Procedures

We not only sell you products but also help you by using our specialized techniques and knowledge!

To address process needs of all kinds, our product range includes tool shanks, cutting tools, blades and auxiliary tools. Also, we never compromise when it comes to attention to details. The important task of CHAIN HEADWAY is to address customers' needs, to which end, good communications and being ready to assist are essential. To fulfill this task, rigorous inspection procedures and standards are in place in terms of both manufacture and inspection. At CHAIN HEADWAY, a diverse range of product and kind professionals are always available.



Tool base / PCD blank



Cutting



Cleaning



Welding

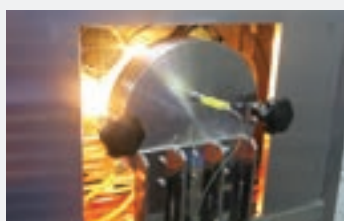

Vacuum Welding



Grinding



QC



Finished Product

Constant Temperature Plant Stable Quality





Complete QC/testing facilities

CHAIN HEADWAY's technical guarantee

Stable production | Efficiency enhancement | Precision grinding | Precision welding
High-optic precision measurement | High-resolution measurement

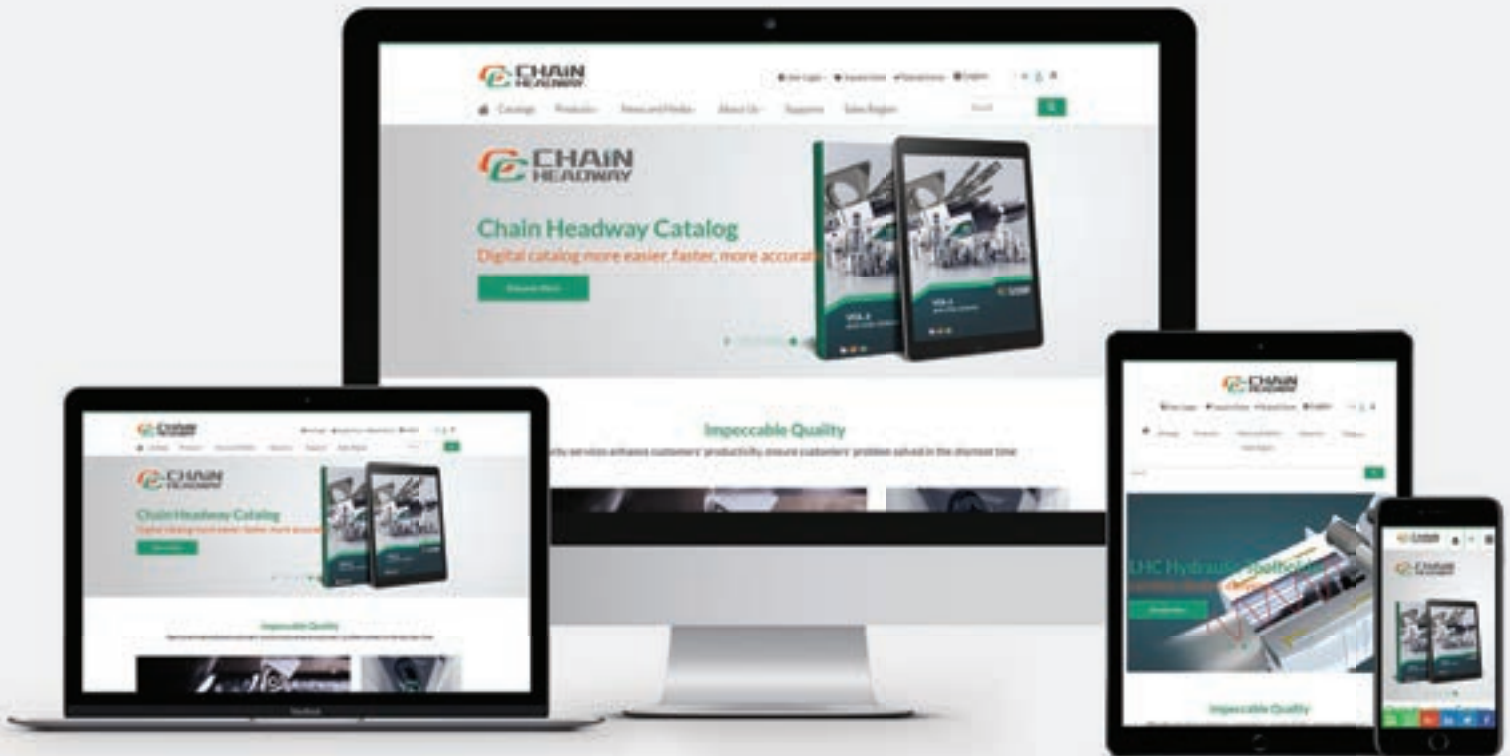

Digitization

Fast information search and data at the fingertip

In the progressive digital era, CHAIN HEADWAY has begun to make digitized services available, such as RWD website (which helps optimize viewing on smart phone), social media propaganda (which helps update the clients regarding latest messages) and electronic catalogues, all allowing the clients to get the information they need quickly and in the easiest manner at any time.





26 Service Bas

Taiwan



Head Office

No. 232, Wuquan Rd., Qingshui Dist., Taichung City 436, Taiwan
Tel : +886-4-26265252 Fax : +886-4-26267941

Taipei Branch

No.26, Ln. 256, Hebian N. St., Sanhong Dist., New Taipei City 241, Taiwan
Tel : +886-2-29788234 Fax : +886-2-29788250

Taichung Branch

No.60, Dongguangyuan Rd., East Dist., Taichung City 401, Taiwan
Tel : +886-4-22809292 Fax : +886-4-22801909

Feng Yuan Branch

No.98, Sec. 1, Yuanhuan N. Rd., Fengyuan Dist., Taichung City 420, Taiwan
Tel : +886-4-25237272 Fax : +886-4-25233232

Miao Li Branch

No.328-1, Bo' ai St., Zhunan Township, Miaoli County 350, Taiwan
Tel : +886-3-7462992 Fax : +886-3-7462248

Tainan Branch

No.269, Zhongshan Rd., Rende Dist., Tainan City 717, Taiwan
Tel : +886-6-2706525 Fax : +886-6-2706527

Philippines

Philippines Branch Office

1st floor half center Unit of Lot C/D Paseo Square De Carmona ,
Governor's Drive , Brgy. Maduya , Carmona , Cavite. Philippines
Tel : (046) 413 9187 / (0917) 583 2702
Mail : JoeAllan@chmt.com.tw
cc-philippines@chmt.com.tw

India

Chennai Branch Office

NO. 52/49A, Dhankotti raja Street, Ekkattuthangal, Chennai, 600032.
India
Tel : +91-9884761375/ +91-8012233925
Mail : cc-india@chmt.com.tw

Presence in the Globe

Head Office



China

China Head Office

Building 3, Huayuan, Longyi, Lujia Town, Kunshan City, Jiangsu Province
Tel : 0512-57874601 Fax : 0512-57874602

Nanjing

Room 902, Unit 2, Building 1, Jinshayayuan, No. 26, Jinshajiang East Street, Jianye District, Nanjing City, Jiangsu Province
Tel : 025-85345030 Fax : 025-85345031

Huai'an

No. 43, Yingbin Boulevard, Jingji Development Area, Huaian City, Jiangsu Province
Tel : 0517-86217575 Fax : 0517-86217272

Dongguan

Room 2002, building No.5, Shi Cheng Han Yuan, No. 451, LuoShi South Road, HongShan district, Wuhan City, Hubei
Tel : 0769-85309396 Fax : 0769-85316029

Foshan

Floor 4, Guangjinlou, Zhonghao Boulevard, Zhongbian Village, Dali Town, Nanhai District, Foshan City, Guangdong Province
Tel : 0757-85505240 Fax : 0757-81184569

Xiamen

Room 1801, No. 10, Yili, Tianan, Jimei District, Xiamen City
Tel : 0592-5653670 Fax : 0592-5653663

Chongqing

No. 71, Fu, Building 34, No. 68, Panlong Boulevard, Jiulongyuan District, Jiulongpo District, Chongqing City, Sichuan Province(C District, Cheng, Jinke Mechanical & Electrical)
Tel : 023-68850991 Fax : 023-68658471

Chengdu

Room 1201, Unit 1, Building 9, B District, No. 199, Yinhe North Street, Jiada Road, Jinniu District, Chengdu City, Sichuan Province
Tel : 18980611190 Fax : 028-61668132

Beijing

Room 1007, Building 206, Wangjinghuayuan East District, Chaoyang District, Beijing City, Hebei Province
Tel : 010-84725668 Fax : 010-84725669

Tianjin

Room 102, Unit 4, Building 39, Jiayuan, Jinhe, Heda Street, Jinzhong, Dabizhuang, Dongli District, Tianjin City, Hebei Province
Tel : 022-84810220 Fax : 022-84810219

Wuhan

Room 2002, building No.5, Shi Cheng Han Yuan, No. 451, LuoShi South Road, HongShan district, Wuhan City, Hubei
Tel : 027-87395596

Zhengzhou

Unit 5, Building 10, Meijing, Xihu, Huagong Road, Gaoxin District, Zhengzhou City, Henan Province
Tel : 0371-55932775 Fax : 0371-67376532

ChangShang

No. 12, F District, Overseas Chinese Economic Development Zone, Changshan, Zhangzhou, Fujian
Tel : 0596-8626668 Fax : 0596-8626669

Dalian

No. 45-1, Lvzhouyuan, Lu, Southwest Of Ganjingzi District, Dalian City, Liaoning Province
Tel : 0411-84357476 Fax : 0411-84357478

Shenyang

605, Block C, No. 58, Huanghe South Avenue, Huanggu District, Shenyang City, Liaoning Province(Zhongjianfenghui Plaza)
Tel : 024-23196266 Fax : 024-23196261

Qingdao

1301, Building 3, Erqi, Chengshihuayuan, No. 2, Nankou Road, Qu, Qingdao City, Shandong Province
Tel : 0532-83027701 Fax : 0532-83029901

Yantai

1505, Xingfu Building B, No. 62, Xingfu Middle Road, Zhifu District, Yantai, Shandong Province
Tel : 0535-4911722 Fax : 0535-4911722

Jinan

No. 3, 6Pai3, Chengnan District, Qixian Culture, Qu, Jinan City, Shandong Province
Tel : 0531-61364589 Fax : 0531-61364467



CHAIN HEADWAY MACHINE TOOLS CO.,LTD

 +886-4-26265252

 +886-4-26267941

 No. 232, Wuquan Rd., Qingshui Dist., Taichung City 436, Taiwan

 www.chain-headway.com

 youtube.com/chmt99

 twitter.com/ChainHeadway

 [facebook.com/ChainHeadway\(Taiwan/Myanmar/Philippines/India\)](https://facebook.com/ChainHeadway(Taiwan/Myanmar/Philippines/India))



LINE



Whatsapp



Wechat

Company Information Please Paste Here

Other Sales Region Please Review Our Website